

# Precision

## BATTERIES

# ADVANCED LITHIUM



[precisionbatteries.com](http://precisionbatteries.com)

V.02-090222





## The Precision Lithium Difference

The Precision Lithium line is unmatched in terms of reliability, safety, performance, and durability. We designed our units to perform as well on the first day as in their tenth year, and our state-of-the-art BMS, cells, and safety functions take recreational lithium batteries to a new level. So whether the batteries are used in southern Florida, Texas, or Arctic Alaska, our batteries will perform time after time.

## Warranty

All Precision batteries include a **headache-free, no-hassles, streamlined** warranty process, unlike most lithium brands on the market which require the user to pay for shipping to and from the manufacturer or require payment for service fees. It's clear in our fine print:

If there is a valid Precision Lithium warranty, the battery will be replaced and delivered to the place of sale at no cost to the customer. Period.

What's classified as a warranty: Any Precision Lithium battery without signs of obvious damage that will not perform to specifications with an approved charger within the warranty period. Period.

That's it! We know our customers spend hard-earned money on these lithium batteries, and we will not deceive our customers with falsely advertised 10, 15, or 20-year warranties.



## Vibration Resistance

With extreme impact and vibration resistance, Precision Lithium is protected with a special coating to ensure the internal components stay intact and secure while in off-road, marine, RV, or any bumpy scenario for the life of the battery.



## Water Protection

Precision lithium cells and Battery Maintenance Systems (BMS) are protected to complete water submersion.



## Fire Supression

Our Lithium cells and Advanced BMS is already one of the safest options available, but Precision takes safety to the next level with built-in fire suppression if something should go wrong.



## Heating Function

Select Precision Lithium Batteries have an automatic built-in cold weather internal heating element. This function protects and prevents damage to Lithium-Ion cells when charging under 32° F.

PART #	VOLTAGE	AH	LCA	ENERGY	WIDTH	LENGTH	HEIGHT	WEIGHT (LBS)	TYPE
PR24V52-DC+HT	25.6	52	N/A	1,331	12.99"	6.77"	8.58"	33.7	DEEP CYCLE
PR52-DC	12.8	52	200	665	5.24"	7.68"	6.73"	17.2	DEEP CYCLE
PR70-DC	12.8	70	200	896	6.61"	10.24"	8.23"	24.5	DEEP CYCLE
PR70-DP	12.8	70	800	896	6.61"	10.24"	8.23"	26.9	DUAL-PURPOSE
PR110-DC+HT	12.8	110	200	1,408	6.61"	10.24"	8.23"	33.73	DEEP CYCLE
PR110-DP+HT	12.8	110	800	1,408	6.77"	12.99"	8.58"	34.17	DUAL-PURPOSE
PR300-DC+HT	12.8	300	300	3,840	7.87"	20.6"	7.15"	93.7	DEEP CYCLE

# PRECISION LITHIUM BATTERIES



## PR24V52-DC+HT

### ELECTRICAL SPECIFICATIONS

Nominal Voltage	12.8V
Nominal Capacity	52Ah
Capacity @ 25A	156 min
Resistance	≤30 mΩ @ 50% SOC
Efficiency	99%
Self Discharge	<3% per Month
Maximum Modules in Series	1 (Single Use)

### DISCHARGE SPECIFICATIONS

Maximum Continuous Discharge Current	50A
Peak Discharge Current	120A (2s)
BMS Discharge Current Cut-Off	200A ± 50A (2 ± 1 ms)
Recommended Low Voltage Disconnect	10V
BMS Discharge Voltage Cut-Off	9.2V (2.3 ± 0.01 vpc) (2 ± 0.5s)
Reconnect Voltage	10V (2.5 ± 0.1 vpc) (2 ± 0.5s)
Short Circuit Protection	200-800 μA

### TEMPERATURE SPECIFICATIONS

Discharge Temperature	-4 to 140 °F (-20 to 60 °C)
Charge Temperature	-4 to 113 °F (-20 to 45 °C)
Storage Temperature	23 to 95 °F (-5 to 35 °C)
BMS High Temperature Cut-Off	167 °F (75 °C)
Reconnect Temperature	122 °F (50 °C)

### MECHANICAL SPECIFICATIONS

Dimensions (L x W x H)	12.99 X 6.77 X 8.58" 330 X 172 X 218 MM
Weight	33.7 lbs (15.3 kg)
Terminal Type	M8 x 1.25 x 2mm
Terminal Torque	80 - 100 in-lbs (9 - 11 N-m)
Case Material	ABS
Enclosure Protection	IP66
Cell Type - Chemistry	Cylindrical - LiFePO4

### CHARGE SPECIFICATIONS

Recommended Charge Current	10A
Maximum Charge Current	50A
Charge Current 14 to 32 °F (-10 to 0 °C)	≤0.3 C
Charge Current -4 to 14 °F (-20 to -10 °C)	≤0.03 C
Recommended Charge Voltage	14.2V - 14.6V
BMS Charge Voltage Cut-Off	15V (3.75 ± 0.05 vpc) (1 ± 0.5 s)
Reconnect Voltage	14.4V (3.6 ± 0.1 vpc)
Balancing Voltage	14.0V (3.5 ± 0.05 vpc)

### COMPLIANCE SPECIFICATIONS

Certifications	UN 38.3 & CE (BATTERY) UL1642 (CELLS) (FILE# MH64443) IEC62133 (CELLS)
Shipping Classification	UN 3480, CLASS 9

### DIMENSIONAL SPECIFICATIONS (MM)

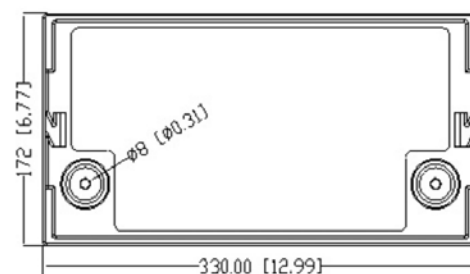
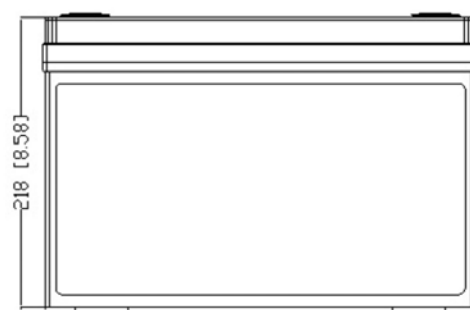

# PRECISION LITHIUM BATTERIES



## PR52-DC

### ELECTRICAL SPECIFICATIONS

Nominal Voltage	12.8V
Nominal Capacity	52Ah
Capacity @ 25A	156 min
Resistance	≤30 mΩ @ 50% SOC
Efficiency	99%
Self Discharge	<3% per Month
Maximum Modules in Series	1 (Single Use)

### DISCHARGE SPECIFICATIONS

Maximum Continuous Discharge Current	50A
Peak Discharge Current	120A (2s)
BMS Discharge Current Cut-Off	200A ± 50A (2 ± 1 ms)
Recommended Low Voltage Disconnect	10V
BMS Discharge Voltage Cut-Off	9.2V (2.3 ± 0.1 vpc) (2 ± 0.5s)
Reconnect Voltage	10V (2.5 ± 0.1 vpc) (2 ± 0.5s)
Short Circuit Protection	200-800 μA

### TEMPERATURE SPECIFICATIONS

Discharge Temperature	-4 to 140 °F (-20 to 60 °C)
Charge Temperature	-4 to 113 °F (-20 to 45 °C)
Storage Temperature	23 to 95 °F (-5 to 35 °C)
BMS High Temperature Cut-Off	167 °F (75 °C)
Reconnect Temperature	122 °F (50 °C)

### MECHANICAL SPECIFICATIONS

Dimensions (L x W x H)	7.68 X 5.24 X 6.73" 195 X 133 X 171 MM
Weight	17.2 lbs (7.8 kg)
Terminal Type	M8 x 1.25 x 2mm
Terminal Torque	80 - 100 in-lbs (9 - 11 N-m)
Case Material	ABS
Enclosure Protection	IP66
Cell Type - Chemistry	Cylindrical - LiFePO4

### CHARGE SPECIFICATIONS

Recommended Charge Current	10A
Maximum Charge Current	50A
Charge Current 14 to 32 °F (-10 to 0 °C)	≤0.03 C
Charge Current -4 to 14 °F (-20 to -10 °C)	≤0.03 C
Recommended Charge Voltage	14.2V - 14.6V
BMS Charge Voltage Cut-Off	15V (3.75 ± 0.05 vpc) (1.5 ± 1.0 s)
Reconnect Voltage	14.6V (3.65 ± 0.05 vpc)
Balancing Voltage	14.5V (3.525 ± 0.05 vpc)

### COMPLIANCE SPECIFICATIONS

Certifications	UN 38.3 & CE (BATTERY) UL1642 (CELLS) (FILE# MH64443) IEC62133 (CELLS)
Shipping Classification	UN 3480, CLASS 9

### DIMENSIONAL SPECIFICATIONS (MM)

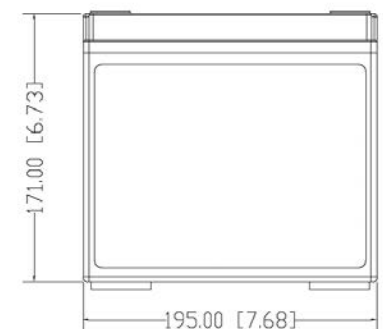
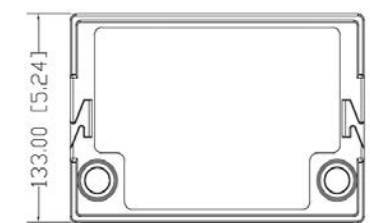

# PRECISION LITHIUM BATTERIES



## PR70-DC

### ELECTRICAL SPECIFICATIONS

Nominal Voltage	12.8V
Nominal Capacity	70Ah
Capacity @ 25A	210 min
Resistance	≤30 mΩ @ 50% SOC
Efficiency	99%
Self Discharge	<3% per Month
Maximum Modules in Series	1 (Single Use)

### DISCHARGE SPECIFICATIONS

Maximum Continuous Discharge Current	100A
Peak Discharge Current	200A (2s)
BMS Discharge Current Cut-Off	300A ± 50A (2 ± 1 ms)
Recommended Low Voltage Disconnect	10V
BMS Discharge Voltage Cut-Off	9.2V (2.3 ± 0.1 vpc) (2 ± 0.5s)
Reconnect Voltage	10V (2.5 ± 0.1 vpc) (2 ± 0.5s)
Short Circuit Protection	200-800 μA

### TEMPERATURE SPECIFICATIONS

Discharge Temperature	-4 to 140 °F (-20 to 60 °C)
Charge Temperature	-4 to 113 °F (-20 to 45 °C)
Storage Temperature	23 to 95 °F (-5 to 35 °C)
BMS High Temperature Cut-Off	167 °F (75 °C)
Reconnect Temperature	122 °F (50 °C)

### MECHANICAL SPECIFICATIONS

Dimensions (L x W x H)	10.24 X 6.61 X 8.23" 260 X 168 X 209 MM
Weight	24.5 lbs (11.1 kg)
Terminal Type	M8 x 1.25 x 2mm
Terminal Torque	80 - 100 in-lbs (9 - 11 N-m)
Case Material	ABS
Enclosure Protection	IP66
Cell Type - Chemistry	Cylindrical - LiFePO4

### CHARGE SPECIFICATIONS

Recommended Charge Current	14A
Maximum Charge Current	70A
Charge Current 14 to 32 °F (-10 to 0 °C)	≤0.03 C
Charge Current -4 to 14 °F (-20 to -10 °C)	≤0.03 C
Recommended Charge Voltage	14.2V - 14.6V
BMS Charge Voltage Cut-Off	15V (3.75 ± 0.05 vpc) (1.5 ± 1.0 s)
Reconnect Voltage	14.6V (3.65 ± 0.05 vpc)
Balancing Voltage	14.5V (3.625 ± 0.05 vpc)

### COMPLIANCE SPECIFICATIONS

Certifications	UN 38.3 & CE (BATTERY) UL1642 (CELLS) (FILE# MH64443) IEC62133 (CELLS)
Shipping Classification	UN 3480, CLASS 9

### DIMENSIONAL SPECIFICATIONS (MM)

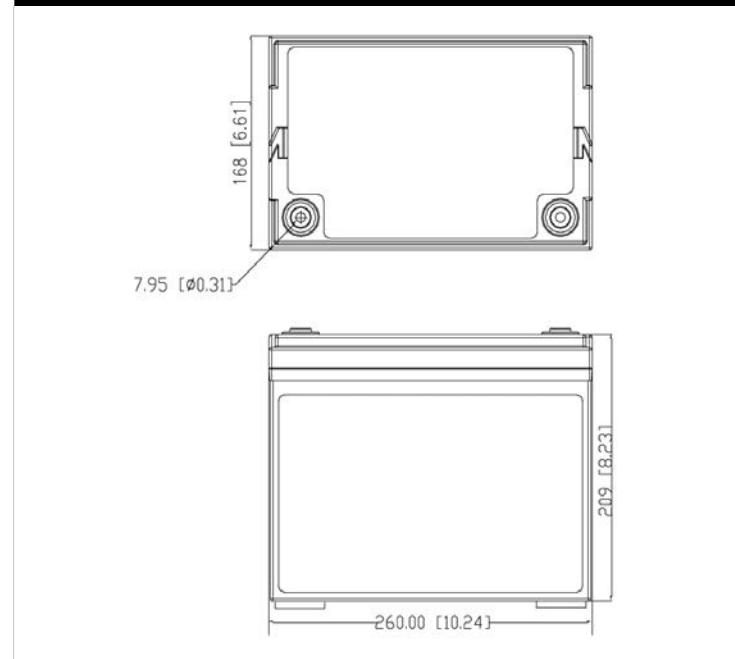

# PRECISION LITHIUM BATTERIES



## PR70-DP

### ELECTRICAL SPECIFICATIONS

Nominal Voltage	12.8V
Nominal Capacity	70Ah
Capacity @ 25A	210 min
Resistance	≤30 mΩ @ 50% SOC
Efficiency	99%
Self Discharge	<3% per Month
Maximum Modules in Series	1 (Single Use)

### DISCHARGE SPECIFICATIONS

Maximum Continuous Discharge Current	100A
Peak Discharge Current	800A (2s)
BMS Discharge Current Cut-Off	1000A ± 100A (2 ± 1 ms)
Recommended Low Voltage Disconnect	10 V
BMS Discharge Voltage Cut-Off	9.2V (2.3 ± 0.1 vpc) (2 ± 0.5s)
Reconnect Voltage	10V (2.5 ± 0.1 vpc) (2 ± 0.5s)
Short Circuit Protection	200-800 μA

### TEMPERATURE SPECIFICATIONS

Discharge Temperature	-4 to 140 °F (-20 to 60 °C)
Charge Temperature	-4 to 113 °F (-20 to 45 °C)
Storage Temperature	23 to 95 °F (-5 to 35 °C)
BMS High Temperature Cut-Off	167 °F (75 °C)
Reconnect Temperature	122 °F (50 °C)

### MECHANICAL SPECIFICATIONS

Dimensions (L x W x H)	10.24 X 6.61 X 8.23" 260 X 168 X 209 MM
Weight	26.9 lbs (12.2 kg)
Terminal Type	M8 x 1.25 x 2mm
Terminal Torque	80 - 100 in-lbs (9 - 11 N-m)
Case Material	ABS
Enclosure Protection	IP66
Cell Type - Chemistry	Cylindrical - LiFePO4

### CHARGE SPECIFICATIONS

Recommended Charge Current	14A
Maximum Charge Current	70A
Charge Current 14 to 32 °F (-10 to 0 °C)	≤0.3 C
Charge Current -4 to 14 °F (-20 to -10 °C)	≤0.03 C
Recommended Charge Voltage	14.2V - 14.6V
BMS Charge Voltage Cut-Off	15V (3.85 ± 0.05 vpc) (1.5 ± 1.0 s)
Reconnect Voltage	14.4V (3.6 ± 0.05 vpc)
Balancing Voltage	/

### COMPLIANCE SPECIFICATIONS

Certifications	UN 38.3 & CE (BATTERY) UL1642 (CELLS) (FILE# MH64443) IEC62133 (CELLS)
Shipping Classification	UN 3480, CLASS 9

### DIMENSIONAL SPECIFICATIONS (MM)

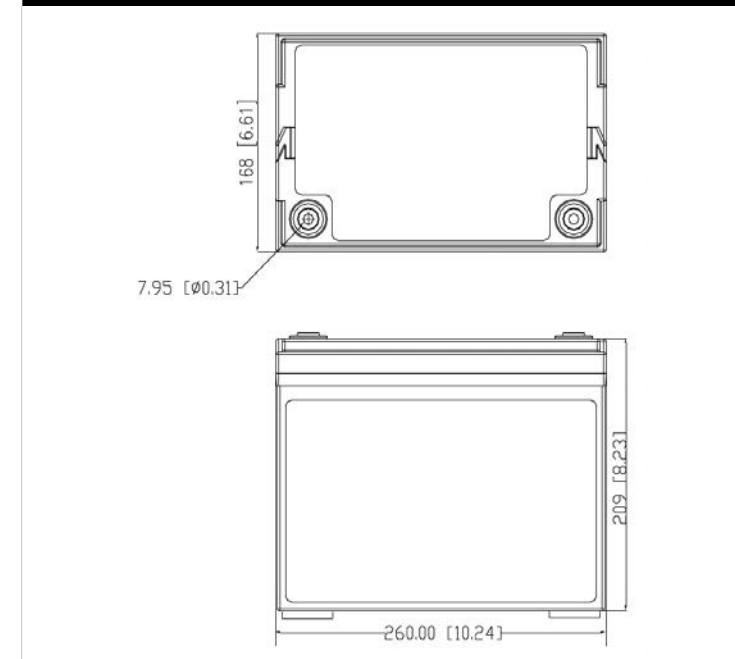



# PRECISION LITHIUM BATTERIES



## PR110-DC+HT

### ELECTRICAL SPECIFICATIONS

Nominal Voltage	12.8V
Nominal Capacity	110Ah
Capacity @ 25A	264 min
Resistance	≤30 mΩ @ 50% SOC
Efficiency	99%
Self Discharge	<3% per Month
Maximum Modules in Series	1 (Single Use)

### DISCHARGE SPECIFICATIONS

Maximum Continuous Discharge Current	100A
Peak Discharge Current	200A (2s)
BMS Discharge Current Cut-Off	300A ± 50A (2 ± 1 ms)
Recommended Low Voltage Disconnect	10 V
BMS Discharge Voltage Cut-Off	9.2V (2.3 ± 0.01 vpc) (2 ± 0.5s)
Reconnect Voltage	10V (2.5 ± 0.1 vpc) (2 ± 0.5s)
Short Circuit Protection	200-800 μA

### TEMPERATURE SPECIFICATIONS

Discharge Temperature	-4 to 140 °F (-20 to 60 °C)
Charge Temperature	-4 to 113 °F (-20 to 45 °C)
Storage Temperature	23 to 95 °F (-5 to 35 °C)
BMS High Temperature Cut-Off	167 °F (75 °C)
Reconnect Temperature	122 °F (50 °C)

### MECHANICAL SPECIFICATIONS

Dimensions (L x W x H)	10.24 X 6.61 X 8.23" 260 X 168 X 209 MM
Weight	33.73 lbs (15.3 kg)
Terminal Type	M8 x 1.25 x 2mm
Terminal Torque	80 - 100 in-lbs (9 - 11 N-m)
Case Material	ABS
Enclosure Protection	IP66
Cell Type - Chemistry	Cylindrical - LiFePO4

### CHARGE SPECIFICATIONS

Recommended Charge Current	20A
Maximum Charge Current	100A
Charge Current 14 to 32 °F (-10 to 0 °C)	≤0.3 C
Charge Current -4 to 14 °F (-20 to -10 °C)	≤0.03 C
Recommended Charge Voltage	14.2V - 14.6V
BMS Charge Voltage Cut-Off	15V (3.75 ± 0.05 vpc) (1.5 ± 1.0 s)
Reconnect Voltage	14.4V (3.6 ± 0.05 vpc)
Balancing Voltage	14.0V (3.5 ± 0.05 vpc)

### COMPLIANCE SPECIFICATIONS

Certifications	UN 38.3 & CE (BATTERY) UL1642 (CELLS) (FILE# MH64443) IEC62133 (CELLS)
Shipping Classification	UN 3480, CLASS 9

### DIMENSIONAL SPECIFICATIONS (MM)

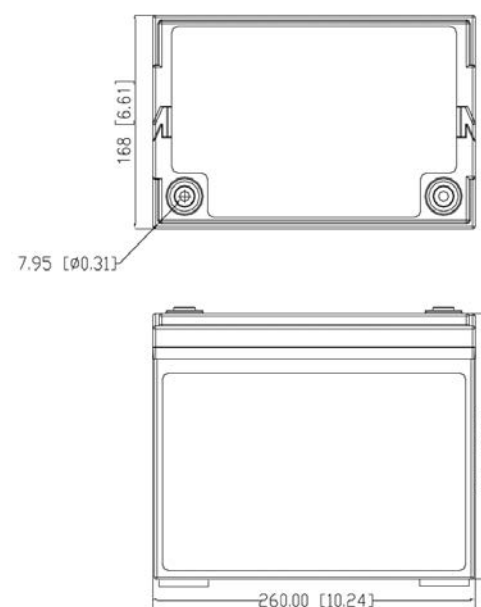

# PRECISION LITHIUM BATTERIES



## PR110-DP+HT

### ELECTRICAL SPECIFICATIONS

Nominal Voltage	12.8V
Nominal Capacity	110Ah
Capacity @ 25A	264 min
Resistance	≤30 mΩ @ 50% SOC
Efficiency	99%
Self Discharge	<3% per Month
Maximum Modules in Series	1 (Single Use)

### DISCHARGE SPECIFICATIONS

Maximum Continuous Discharge Current	100A
Peak Discharge Current	800A (2s)
BMS Discharge Current Cut-Off	1000A ± 100A (2 ± 1 ms)
Recommended Low Voltage Disconnect	10 V
BMS Discharge Voltage Cut-Off	9.2V (2.3 ± 0.01 vpc) (2 ± 0.5s)
Reconnect Voltage	10V (2.5 ± 0.1 vpc) (2 ± 0.5s)
Short Circuit Protection	200-800 μA

### TEMPERATURE SPECIFICATIONS

Discharge Temperature	-4 to 140 °F (-20 to 60 °C)
Charge Temperature	-4 to 113 °F (-20 to 45 °C)
Storage Temperature	23 to 95 °F (-5 to 35 °C)
BMS High Temperature Cut-Off	167 °F (75 °C)
Reconnect Temperature	122 °F (50 °C)

### MECHANICAL SPECIFICATIONS

Dimensions (L x W x H)	12.99 X 6.77 X 8.58" 330 X 172 X 218 MM
Weight	34.17 lbs (15.5 kg)
Terminal Type	M8 x 1.25 x 2mm
Terminal Torque	80 - 100 in-lbs (9 - 11 N-m)
Case Material	ABS
Enclosure Protection	IP66
Cell Type - Chemistry	Cylindrical - LiFePO4

### CHARGE SPECIFICATIONS

Recommended Charge Current	20A
Maximum Charge Current	100A
Charge Current 14 to 32 °F (-10 to 0 °C)	≤0.3 C
Charge Current -4 to 14 °F (-20 to -10 °C)	≤0.03 C
Recommended Charge Voltage	14.2 V - 14.6 V
BMS Charge Voltage Cut-Off	15V (3.75 ± 0.05 vpc) (1 ± 0.5 s)
Reconnect Voltage	14.4V (3.6 ± 0.1 vpc)
Balancing Voltage	14.0V (3.5 ± 0.05 vpc)

### COMPLIANCE SPECIFICATIONS

Certifications	UN 38.3 & CE (BATTERY) UL1642 (CELLS) (FILE# MH64443) IEC62133 (CELLS)
Shipping Classification	UN 3480, CLASS 9

### DIMENSIONAL SPECIFICATIONS (MM)

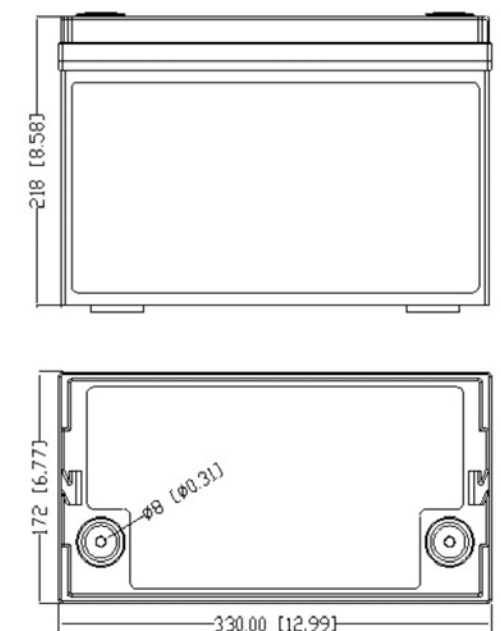



## PR300-DC+HT

### ELECTRICAL SPECIFICATIONS

Nominal Voltage	12.8V
Nominal Capacity	110Ah
Capacity @ 25A	720 min
Resistance	≤30 mΩ @ 50% SOC
Efficiency	99%
Self Discharge	<3% per Month
Maximum Modules in Series	1 (Single Use)

### DISCHARGE SPECIFICATIONS

Maximum Continuous Discharge Current	200A
Peak Discharge Current	250A (2s)
BMS Discharge Current Cut-Off	320A ±50 A (2 ±1 ms)
Recommended Low Voltage Disconnect	10 V
BMS Discharge Voltage Cut-Off	9.2V (2.3 ±0.01 vpc) (2 ± 0.5s)
Reconnect Voltage	10V (2.5 ± 0.1 vpc) (2 ± 0.5s)
Short Circuit Protection	200-800 μA

### TEMPERATURE SPECIFICATIONS

Discharge Temperature	-4 to 140 °F (-20 to 60 °C)
Charge Temperature	-4 to 113 °F (-20 to 45 °C)
Storage Temperature	23 to 95 °F (-5 to 35 °C)
BMS High Temperature Cut-Off	167 °F (75 °C)
Reconnect Temperature	122 °F (50 °C)

### MECHANICAL SPECIFICATIONS

Dimensions (L x W x H)	20.6 X 7.87 X 7.15" 522 X 240 X 215 MM
Weight	93.7 lbs (42.5 kg)
Terminal Type	M8 x 1.25 x 2mm
Terminal Torque	80 - 100 in-lbs (9 - 11 N-m)
Case Material	ABS
Enclosure Protection	IP66
Cell Type - Chemistry	Cylindrical - LiFePO4

### CHARGE SPECIFICATIONS

Recommended Charge Current	60A
Maximum Charge Current	200A
Charge Current 14 to 32 °F (-10 to 0 °C)	≤0.3 C
Charge Current -4 to 14 °F (-20 to -10 °C)	≤0.03 C
Recommended Charge Voltage	14.2 V - 14.6 V
BMS Charge Voltage Cut-Off	15V (3.75 ±0.05 vpc) (1.5 ± 1.0 s)
Reconnect Voltage	14.4V (3.6 ±0.05 vpc)
Balancing Voltage	14.0V (3.5 ±0.05 vpc)

### COMPLIANCE SPECIFICATIONS

Certifications	UN 38.3 & CE (BATTERY) UL1642 (CELLS) (FILE# MH64443) IEC62133 (CELLS)
Shipping Classification	UN 3480, CLASS 9

### DIMENSIONAL SPECIFICATIONS (MM)

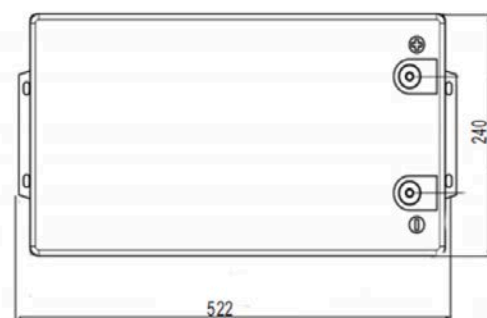

Charging Characteristics at different rates at 25 °C (77 °C)

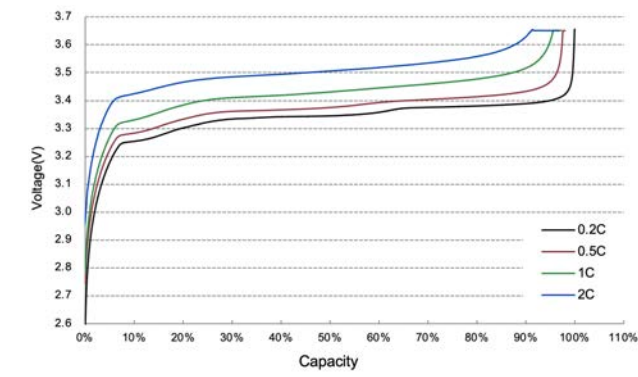

Charging Characteristics at different temperatures at 25 °C (77 °C)

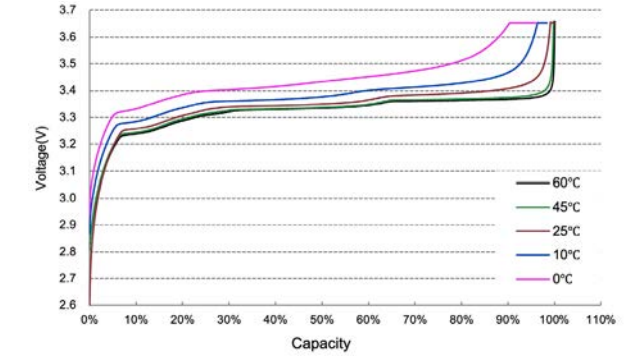

Discharging Characteristics at different rates at 25 °C (77 °C)

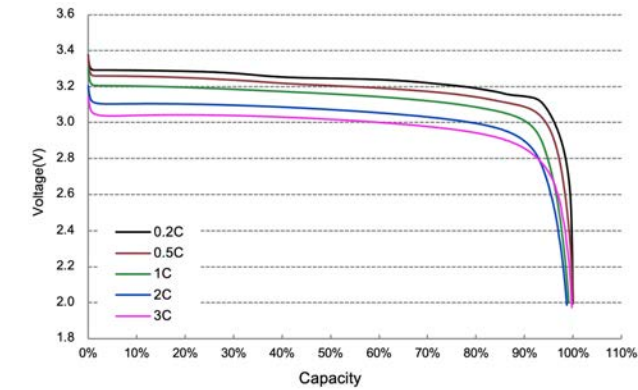

Discharging Characteristics at different temperatures at 25 °C (77 °C)

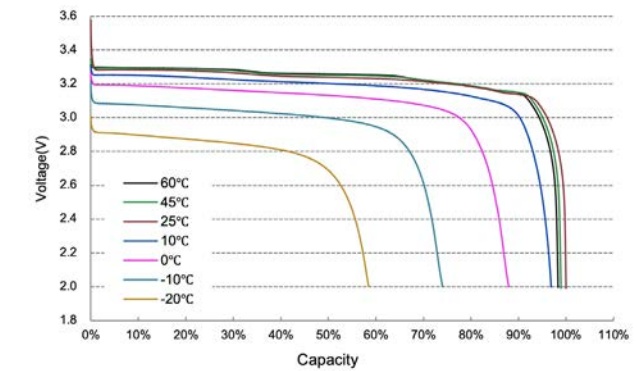

Cyclic Characteristics

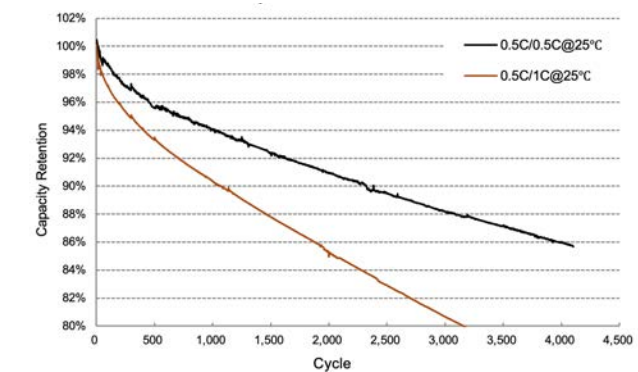

Capacity of Precision LiFePO4 vs. Lead Acid at Various Rates of Discharge

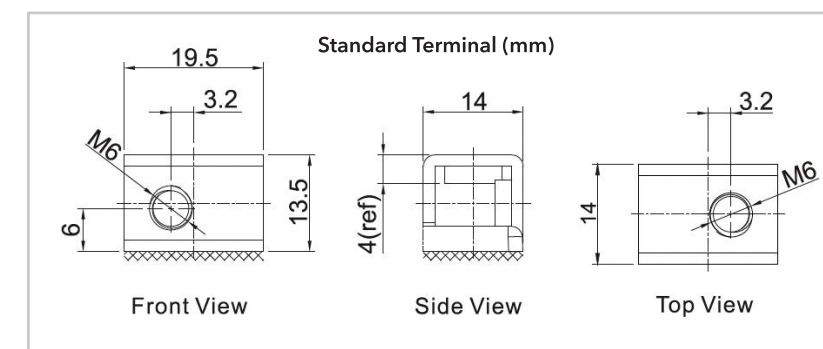
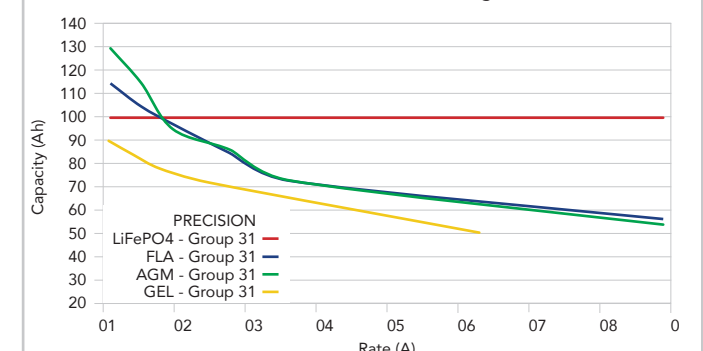



## PRO Charging Systems

### REAL PRO SERIES



#### Product Features

RealPro Series battery chargers are an affordable, reliable and safe battery charging system designed for everyday use. The system is engineered for users who need a charging system on an occasional basis and may not want or need the capabilities of a heavier duty and higher amperage product. It is designed for use in many types of applications including bass boats, runabouts, pontoon boats, other watercraft, automobiles, ATVs, golf carts and other similar uses. The system delivers sophisticated capabilities and superior value to customers.

Charges Wet Cell, AGM and most Lithium Batteries\*  
 Designed for use in fresh and salt water  
 Dependable, rugged construction and waterproof  
 Independent outputs and fully automatic  
 Battery maintenance mode  
 Two year warranty  
 DC charge cables = 5ft and AC power cord = 3ft  
 Approved and meets ISO 8846 Marine standards  
 6 AMP Banks  
 Models available to charge 12-24V systems  
 LED lights indicate "Each Battery's" state of charge  
 Reverse polarity protected and no installation restrictions  
 Ignition protected (US Coast Guard 33 CFR 183.410)  
 FCC 15 Parts A and B Interference Compliant

### SPORTSMAN SERIES



#### Product Features

The Sportsman Series of chargers have set the standard for advanced capability and reliability in the marine/watercraft market segment. Today, they continue to be the safest, most reliable, and best performing battery chargers available on the market. Across a broad range of fishing and recreational boats, Pro Charging Systems keeps boaters on the water longer while extending the life of their batteries. Dual Pro charging technology has been and continues to be the choice of over 50 boat manufacturers and professional fishermen on the B.A.S.S. and FLW tournament circuit.  
**Applications: Inland Watercraft, Saltwater Watercraft, Golf Carts, Utility Carts and more.**

PROVolt® Models for Wet Cell and AGM batteries  
 AUTOPROFILE Models for Lithium\* and AGM batteries (More product features below)  
 10 AMP Banks  
 Designed for use in fresh and saltwater  
 PROVolt® Intuitive Charging Technology  
 Waterproof, dependable, rugged construction  
 Independent outputs  
 Fully automatic / multi stage charging  
 Zero spark technology  
 Battery maintenance mode  
 On-board diagnostic codes  
 Temperature compensated  
 Advanced microprocessor controlled  
 Battery systems available: 12V – 48V  
 LED lights indicate the state of charge  
 Reverse polarity protected  
 No installation restrictions  
 FCC Parts A & B interference compliant  
 DC charge cables = 5ft. AC power cord = 3ft.  
 Approved and meets ISO 8846 Marine standards  
 Ignition protected (US Coast Guard 33 CFR 183.410)

### PROFESSIONAL SERIES



#### Product Features

For more than twenty years, the Professional Series of chargers have set the standard for advanced capability and reliability in the marine/watercraft market segment. Today, they continue to be the safest, most reliable, and best performing battery chargers available on the market. Across a broad range of fishing and recreational boats, Pro Charging Systems keeps boaters on the water longer while extending the life of their batteries. Dual Pro charging technology has been and continues to be the choice of over 50 boat manufacturers and professional fishermen on the B.A.S.S. and FLW tournament circuit. **Applications: Inland Watercraft, Saltwater Watercraft, Golf Carts, Utility Carts and more.**

PROVolt® Models for Wet Cell and AGM batteries  
 AUTOPROFILE Models for Lithium\* and AGM batteries (More product features below)  
 15 AMP Banks  
 Designed for use in fresh and saltwater  
 PROVolt® Intuitive Charging Technology  
 Waterproof, dependable, rugged construction  
 Independent outputs  
 Fully automatic / multi stage charging  
 Zero spark technology  
 Battery maintenance mode  
 On-board diagnostic codes  
 Temperature compensated  
 Advanced microprocessor controlled  
 Battery systems available: 12V – 48V  
 LED lights indicate the state of charge  
 Reverse polarity protected  
 No installation restrictions  
 FCC Parts A & B interference compliant  
 DC charge cables = 5ft. AC power cord = 3ft.  
 Approved and meets ISO 8846 Marine standards  
 Ignition protected (US Coast Guard 33 CFR 183.410)

### DUAL POWER SERIES



#### Product Features

The Sportsman Series of chargers have set the standard for Pro Charging Systems new Dual Power Series of chargers simultaneously charges your main battery independently and the rest of your batteries in series. The result is fast, dependable and efficient charging. The product also leverages powerful exclusive technologies to further enhance the energy management status of fresh and saltwater boats. Available in 36V/12V configuration.

Dynamic Intelligent High Frequency Charging  
 Charges Wet Cell, AGM, Gelled Electrolyte and most Lithium Batteries\*  
 Charges Main Battery Independently and Additional Batteries in Series  
 Quickly and Efficiently Charges and Conditions Batteries  
 Smaller Form Factor and only 12 lbs  
 IP67 & IP68 Pending  
 89% Overall Efficiency  
 .98 Power Factor  
 Communicates with Smartphones via DeltaView® Link App

# NOCO GENIUS CHARGERS



**NOCO genius**

## 12V GEN 5 SERIES

### Product Features

**100% Waterproof.** Ignition protected (US Coast Guard 33 CFR 183.410) and designed to withstand hours underwater. On-board chargers built for extreme conditions.

**Force Mode.** For extremely dead batteries lower than 1 volt, manually turn on force mode to detect and charge batteries all the way down to zero volts.

**Zero Overcharge.** Safely charge any battery year-round. Charge continuously without user intervention and with zero risk of overcharging your battery.

**Multi-Chemistry. Multi-Type.** Charge flooded, gel, maintenance-free, AGM, and lithium batteries. For use with charter, deep-cycle, marine batteries, and more.

### 5 CHARGING MODES

#### 12V

for wet cell, gel, enhanced flooded, maintenance-free, and calcium batteries

#### AGM

used for 12V AGM or maintenance-free batteries.

#### LITHIUM

or 12V lithium-ion batteries. For batteries with Battery Management Systems (BMS).

#### REPAIR

Used to repair old, idle, damaged, stratified, or sulfated batteries.

#### FORCE MODE

Used to charge batteries below 1V. For batteries with Battery Management Systems (BMS).



#### GEN 5X1

#### GEN 5X2

#### GEN 5X3

	GEN 5X1	GEN 5X2	GEN 5X3
<b>Charging Current</b>	5A	10A	15A
<b>Current Per Bank</b>	5A	5A	5A
<b>Output Power</b>	72W	145W	220W
<b>Charging Banks</b>	1	2	3
<b>Dimensions</b>	4.6" x 2.9" x 1.9"	6.4" x 4.7" x 2.1"	7.1" x 5.7" x 2.2"
<b>Weight</b>	1.85 lbs	4.17 lbs	5.76 lbs

# NOCO GENIUS CHARGERS

**NOCO genius**

## 12V GENPRO 10 SERIES

### Product Features

**100% Waterproof.** Ignition protected (US Coast Guard 33 CFR 183.410) and designed to withstand hours underwater. On-board chargers built for extreme conditions.

**Force Mode.** For extremely dead batteries lower than 1 volt, manually turn on force mode to detect and charge batteries all the way down to zero volts.

**Zero Overcharge.** Safely charge any battery year-round. Charge continuously without user intervention and with zero risk of overcharging your battery.

**Multi-Chemistry. Multi-Type.** Charge flooded, gel, maintenance-free, AGM, and lithium batteries. For use with charter, deep-cycle, marine batteries, and more.



### 5 CHARGING MODES

#### 12V

for wet cell, gel, enhanced flooded, maintenance-free, and calcium batteries

#### AGM

used for 12V AGM or maintenance-free batteries.

#### LITHIUM

or 12V lithium-ion batteries. For batteries with Battery Management Systems (BMS).

#### REPAIR

Used to repair old, idle, damaged, stratified, or sulfated batteries.

#### FORCE MODE

Used to charge batteries below 1V. For batteries with Battery Management Systems (BMS).



#### GENPRO 10X1

#### GENPRO 10X2

#### GENPRO 10X4

	GENPRO 10X1	GENPRO 10X2	GENPRO 10X4
<b>Charging Current</b>	20A	30A	40A
<b>Current Per Bank</b>	10A	10A	10A
<b>Output Power</b>	300W	450W	600W
<b>Charging Banks</b>	2	3	4
<b>Dimensions</b>	5.7" x 5.8" x 2.9"	10.5" x 7.4" x 2.8"	11.3" x 8.3" x 2.8"
<b>Weight</b>	7.2 lbs	12.8 lbs	15.5 lbs



## FREQUENTLY ASKED QUESTIONS

### SIZING/SELECTION

#### Q: Will Precision batteries work in my Trolling motor?

Precision deep-cycle batteries 52A and greater are designed to work with all production Trolling Motors. Please consult your specification sheet for larger current drains.

#### Q: Will Precision batteries work in my RV?

Yes, most consumers select the PR110-DC+HT or the PR70-DC

#### Q: What is the minimum quantity of batteries needed for my trolling motor or boat motor?

12V trolling motor	1
24V trolling motor	2
36V trolling motor	3
12 v Starting Battery	1

#### Q: Do I need to use the Lithium Starting battery if I purchase Precision Lithium deep-cycle batteries?

We recommend the Precision starting batteries for extended accessory runtime and faster charging than lead batteries.

#### Q: Can I use different types (Flooded, AGM, Lithium) batteries in my boat, RV, or Solar System for Deep-Cycle applications?

Yes, if there is a defective lithium unit, then adding a Flooded or AGM battery short-term in the battery bank will not cause any damage to either setup, but you cannot mix Lithium and Lead in series connections for long-term use. Also, ensure you use the same SKU battery per bank.

#### Q: Can I use different types (Flooded, AGM, Lithium) batteries in starting applications.

Yes, adding a flooded or AGM (Lead) battery in parallel can protect the lithium battery from momentary peak alternator current & voltage.

*Please note: The lead battery should connect to the lithium battery in parallel as a stand-alone battery. Then, install the lithium battery as the main battery with all wires, charger, alternator, starter, etc.... connected to the lithium battery terminals.*

#### Q: Are my Precision Lithium batteries drop-in replacements?

Yes, Precision Lithium batteries have physically similar dimensions as Lead and AGM. Group 24, 27, and 31.

### INSTALLATION

#### Q: How should I install my Precision Lithium batteries?

The battery is a direct replacement and should be installed the same as the existing batteries.

#### Q: What size cables/wiring do I need to connect my Precision Lithium batteries?

Refer to the Original Equipment Manufacturer's specifications for wire size required to operate your electrical components and motors.

### CHARGING

#### Q: What charger do you recommend for marine applications?

We recommend using a multi-bank charger to ensure each battery is balanced correctly and receives a full charge. Chargers with a lithium charge profile are required; Lead battery chargers may charge the lithium battery, but doing so will harm the lithium cells. Please consult your Precision Lithium dealer for approved lithium charger models.

#### Q: I do not have a multi-bank charger for my RV. How should I charge my lithium batteries?

If the stock converter in your RV was designed for Lead/ AGM and not Lithium, then please speak with your local dealer about upgrading to a lithium option. Most lead battery converters can charge a lithium battery, but the algorithm can decrease the battery's lifespan and fail to charge a fully depleted lithium battery.

#### Q: What charger/charge controller do I need for solar applications?

Please ensure the Charge Controller/ Converter/ Inverter has a lithium charge profile. The recommended charge voltage is 14.2V, and the recommended charge current is .3-.5C.

#### Q: Can I use any charge profile to charge my batteries?

No. AGM or Lead charging profile can charge a lithium battery that is not fully depleted, but it will harm lithium cells and reduce the battery's overall lifespan. Lithium chargers use algorithms that properly balance and charge the lithium cells.

#### Q: Can I charge multiple batteries in series or parallel with a single set of charge leads (single-bank charger)?

It's recommended to use a multi-bank charger to ensure each battery receives the proper charge. If a multi-bank charger is not available, connect the charger to the positive terminal of one battery and the negative terminal of the furthest distance battery in the bank. (See diagram at the end of this section on page 2)

#### Q: How long will it take my batteries to charge?

The time it takes to charge your batteries depends on the percent discharged and the charger's output current (Amps), and the total capacity of your battery. Typically, a 10A charger will fully charge a depleted 100A battery in 10 hours.

#### Q: Do I need to charge my Precision Lithium batteries after each use?

It is recommended to fully charge your batteries after each use to ensure full capacity for subsequent uses. Storing lithium batteries under 20% charged can damage the cells or BMS and reduce their overall lifespan.

#### Q: How long can I leave my charger connected to my batteries?

Please refer to the charger's instruction manual.

#### Q: What is the recommended charging temperature range of Precision Lithium Batteries?

-25°F to 104°F if the battery has a built-in heating function.  
32°F to 113°F If the battery does not have a built-in heater.  
Charging temps of 10°F to 113°F are acceptable if using a charger with less than 10% of the battery's capacity. Example: 10% of a 100-amp battery is ten amps.

#### Q: Why is my battery not charging after the battery was completely discharged?

The battery management system will enter " low-voltage protection mode" (sleep mode) to safeguard itself from possible damage. If the battery is completely drained of capacity (power/ampage), a battery charger with a Lithium charge profile and wake-up feature must be used to recharge the battery fully. Standard flooded lead acid or AGM chargers do not have the "smarts" to charge lithium batteries properly. - Please consult your local Precision dealer for charger selections.

## FREQUENTLY ASKED QUESTIONS

### SERIES: Double Voltage & Same Amperage

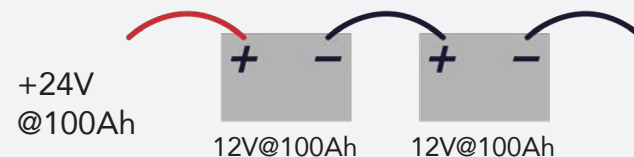

### PARALLEL: Same Voltage & Double Amperage

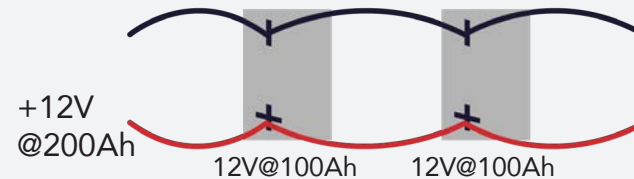

### OPERATION

#### Q: What is the expected runtime of my Precision Lithium battery?

The runtime will vary depending on the amp draw and other conditions, such as the general operation of electronic equipment. Example: One Precision Lithium group 24 110-Amp battery will run approximately 40-50% longer than a group 31 110-amp flooded lead-acid or AGM battery.

#### Q: How far can I discharge my Precision Lithium starting/dual-purpose battery before it can't start my engine?

If your battery is more than 80% discharged, you may experience issues starting your motor. If users feel their battery is getting low on power, they should start their motor and recharge the battery with the alternator.

#### Q: What purpose does the heating function serve

Charging a lithium battery under 32°F can damage the lithium cells. Therefore, the heating function automatically diverts the current (power from the charger) from the lithium cells to an internal heating element to warm the cells to a proper temperature before charging initiates.

#### Q: Can I mix batteries in my boat?

It is not recommended to mix varying amp-hour or chemistry of batteries for the same application. Deep-cycle batteries should be the same SKU for each bank. And Starting batteries should be the same SKU when connected in parallel. -Other than noted in the Sizing/Selection portion of this sheet.

#### Q: How long will my batteries last?

With proper care, expect 5,000 discharge/charge cycles at 80% depth of discharge at 77°F. The average Flooded or AGM marine battery life expectancy is 100-300 discharge/charge cycles at 80% depth of discharge at 77°F.

#### Q: Will my existing battery gauge work on my Precision Lithium battery?

Not if it's a lead-acid battery gauge. Lithium and Flooded/AGM batteries have slightly different voltages (12V for Lead and 12.8V for Lithium), so the reading of the Lead battery gauge is inaccurate on Lithium batteries.

#### Q: Are my Precision Lithium batteries water-resistant?

Yes, the case of the battery is IP66, while the internal components are fully coated to protect against water submersion.

#### Q: Are my Precision Lithium batteries fire resistant?

Yes, Our batteries utilize a BMS to protect the battery and user from certain abuse. In addition, Precision Lithium cells are designed to be one of the safest lithium options available, the plastic box is V0 fire-rated, and the internal components are covered with a V0 rated heat-dissipating/ fire suppressing sealant/ waterproofing.

#### Q: Do my batteries have peak limitations?

Yes, please refer to the datasheet for your battery model.

### STORAGE

#### Q: How do I store my Precision Lithium batteries?

Fully charge your batteries before storage.

Unhook the main negative to prevent any drain on the batteries. If stored in areas where it drops below 23°F for multiple days, then it is recommended to keep the batteries in a climate-controlled room.

#### Q: What is the recommended storage temperature of Precision Lithium Batteries?

Between 23 and 95 degrees F.

#### Q: What is Precision Lithium batteries' recommended operating ambient (discharge) temperature?

-4 to 104 degrees F.

The Continental Battery Systems warranty policy requires a receipt from the original purchaser. The date of this receipt establishes the beginning date of service used for the Continental Battery Systems warranty, which offers a five-year (60 months) free replacement if using an approved charger, 30-day free replacement if not using an approved charger, or 30-day undamaged return policy for all PRECISION ADVANCE LITHIUM branded batteries. We do not offer a lifetime warranty. If the Precision Advance Lithium battery is replaced under the warranty policy, your replacement battery carries a warranty period from the original Precision Advance Lithium battery purchase date.

For technical or warranty support, please call the lithium support line: (800) 929-6054.

# Precision

**BATTERIES**



[precisionbatteries.com](http://precisionbatteries.com)

*Designed in the USA*



Distributed by:

**Continental**  
BATTERY SYSTEMS

[www.gocbs.com](http://www.gocbs.com)